

Polyex

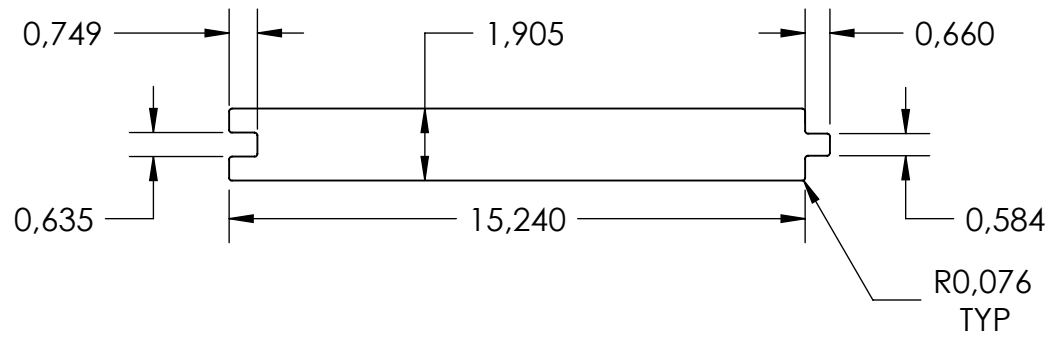

Polyex

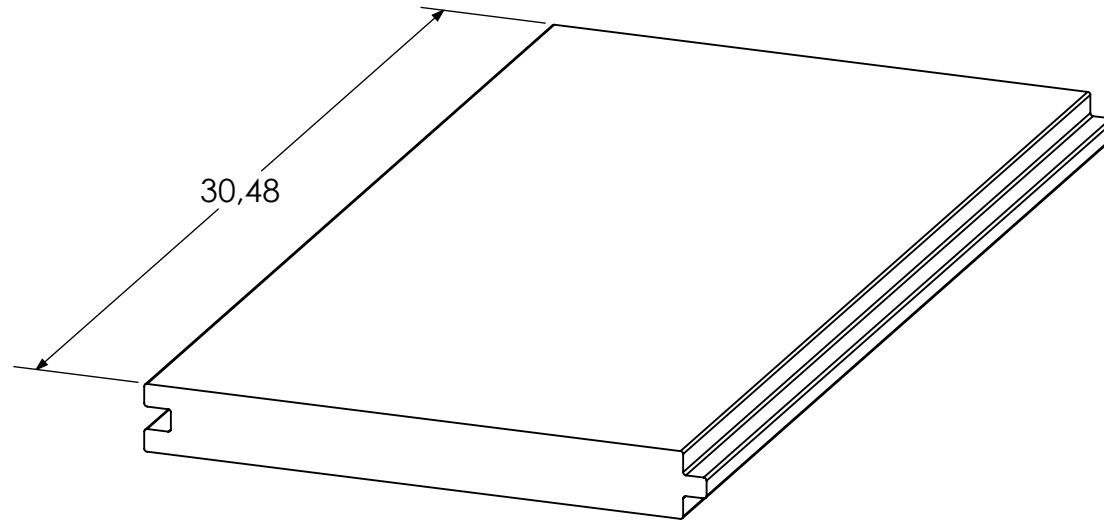
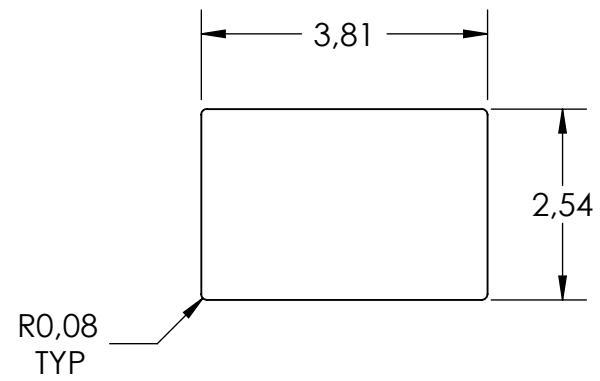
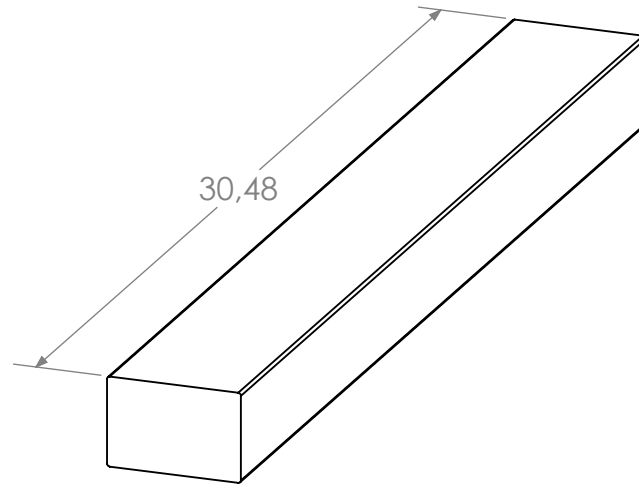

Polyex

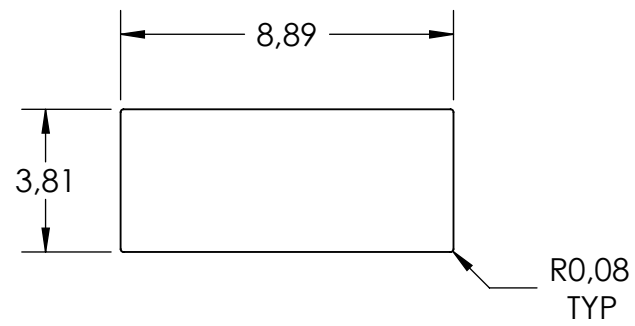
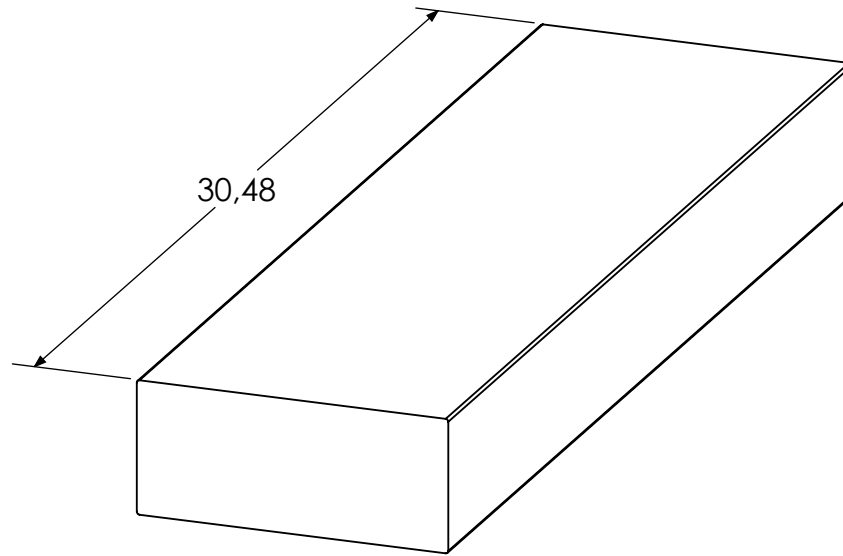

Polyex

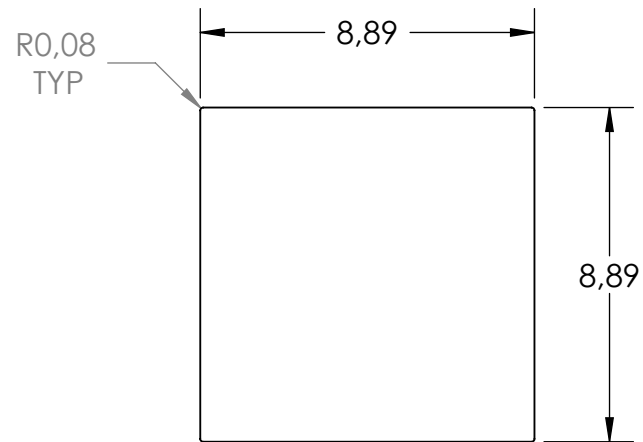
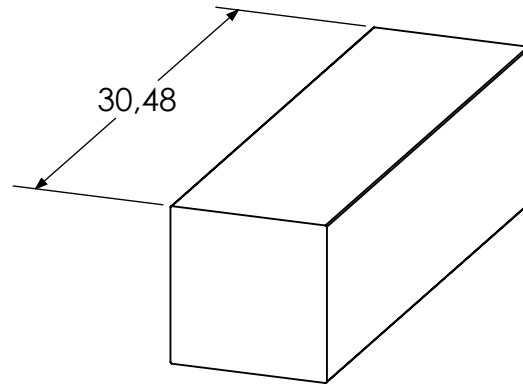

Polyex

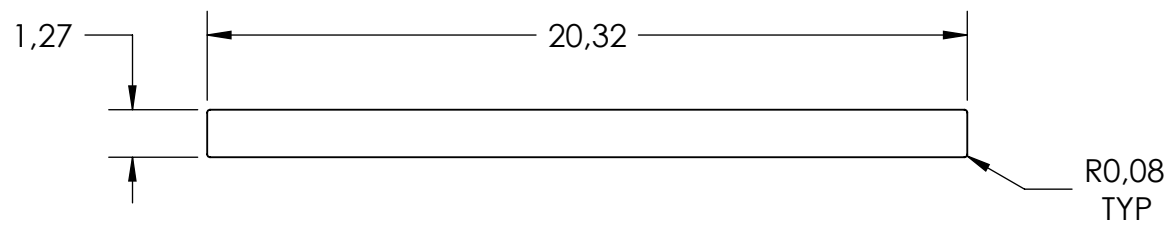
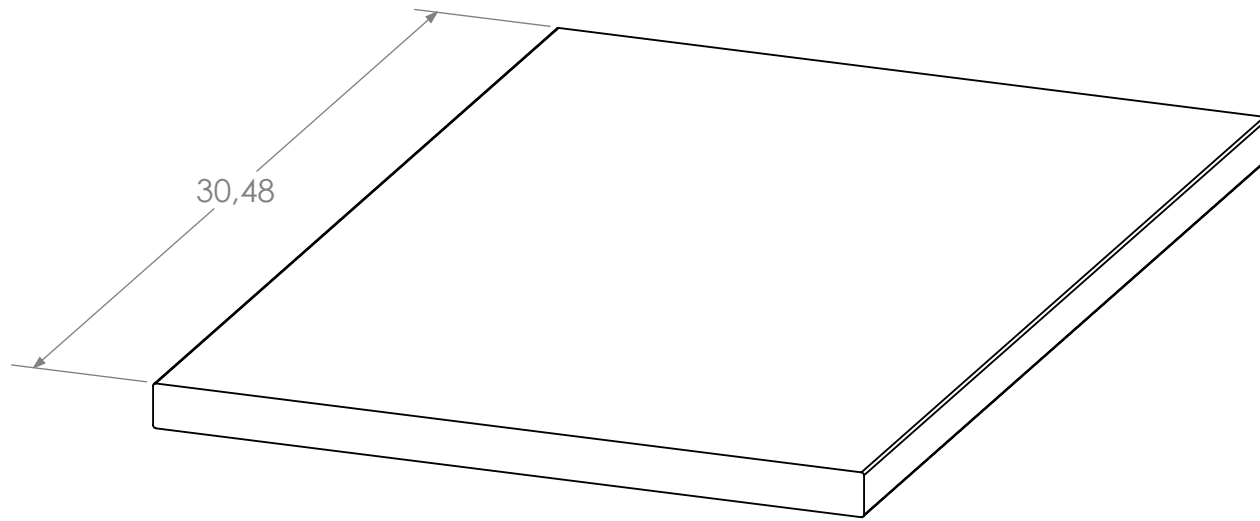

Polyex

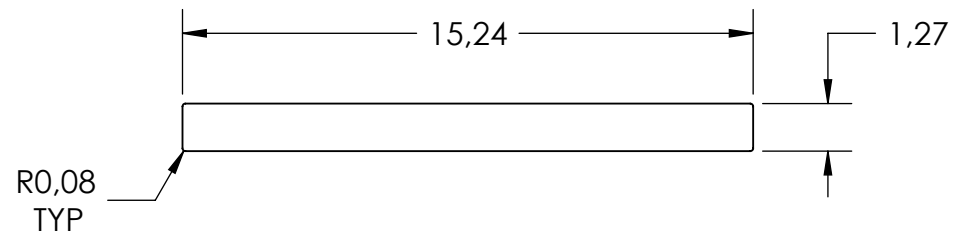
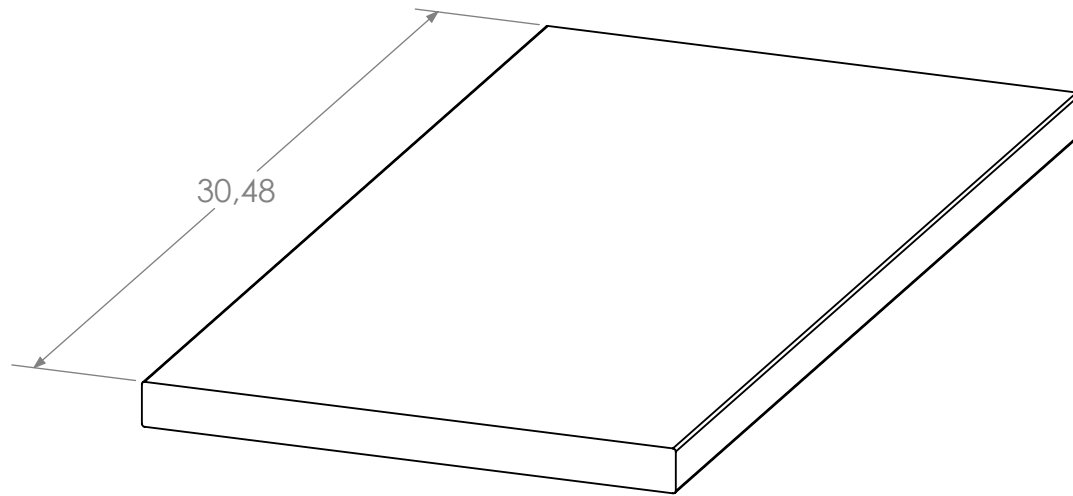

Polyex

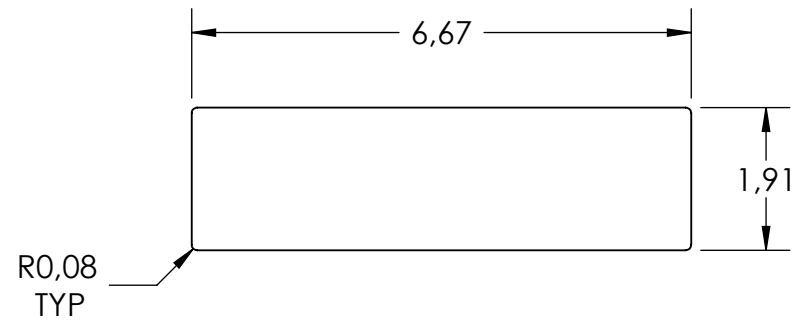
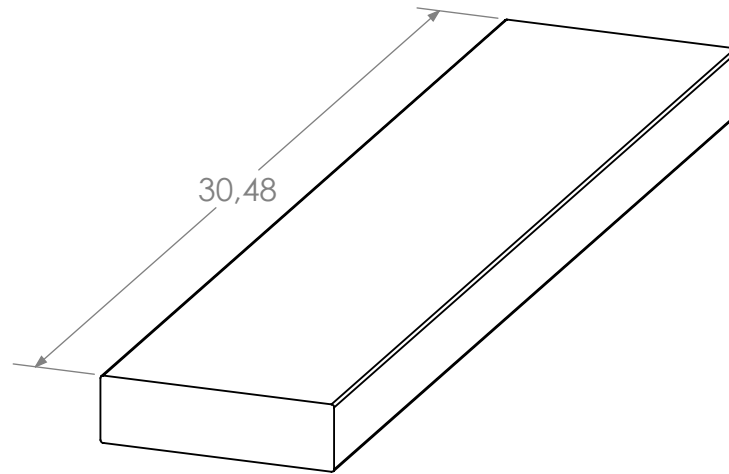

Polyex

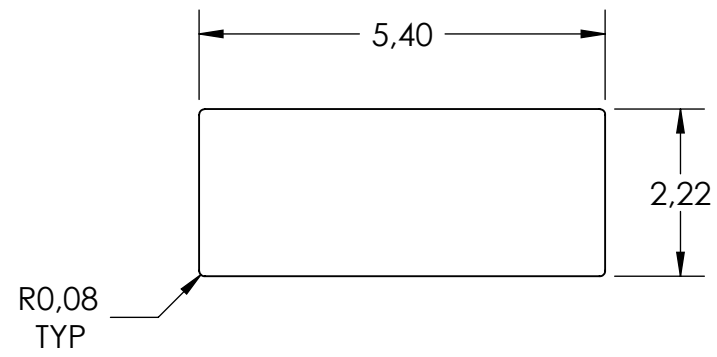
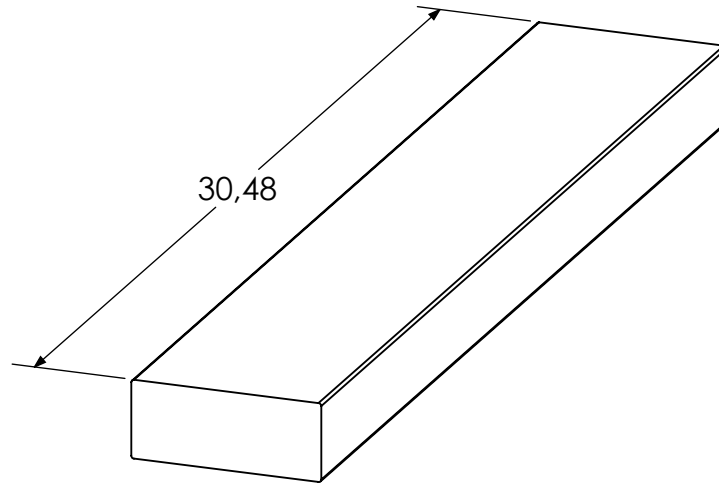

Polyex

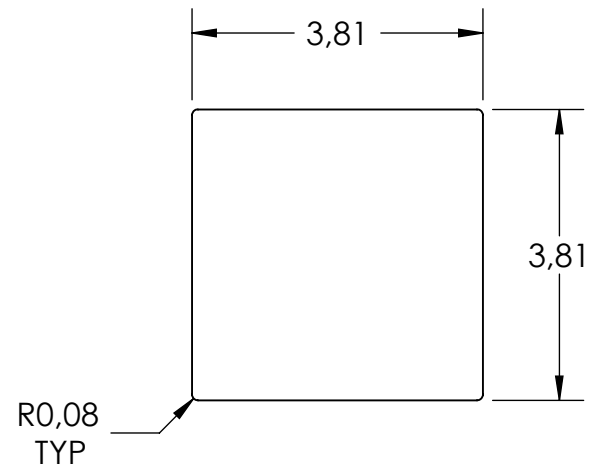
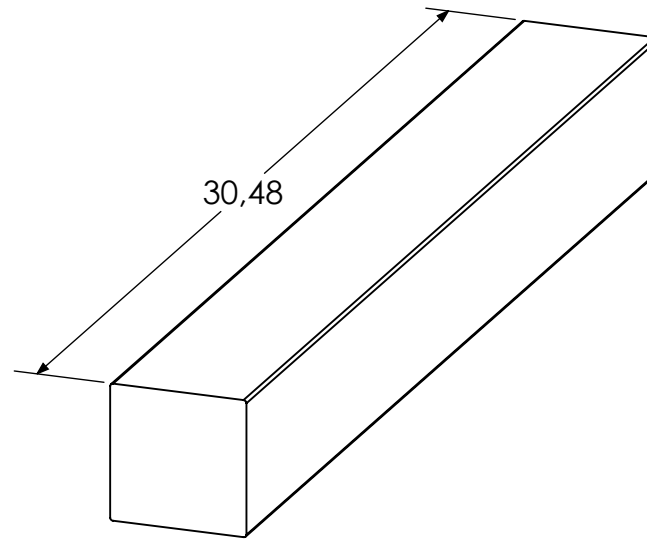

Polyex

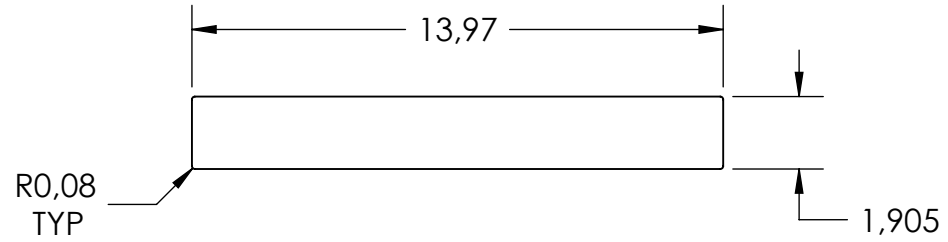
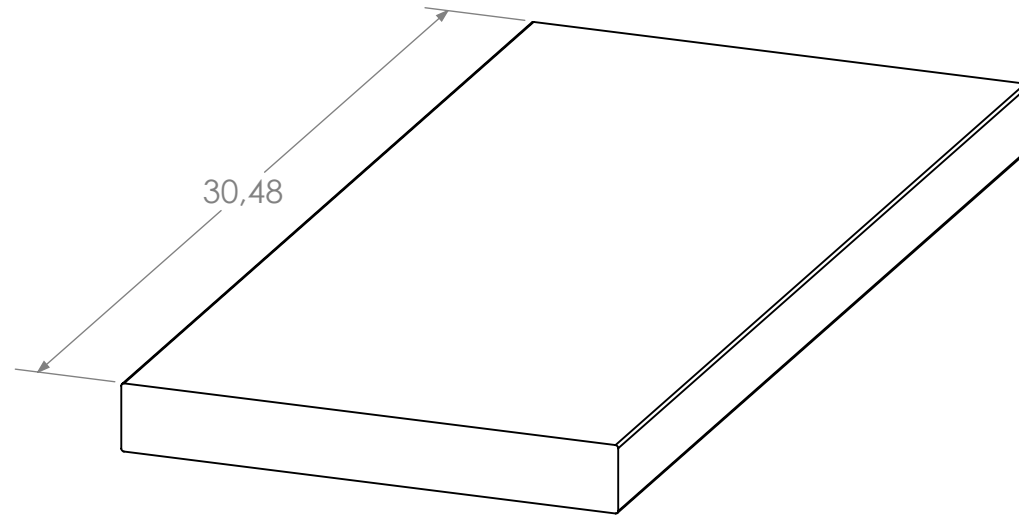

Polyex

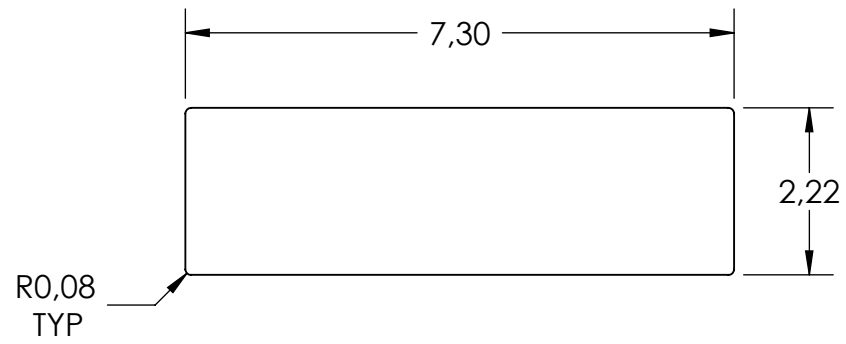
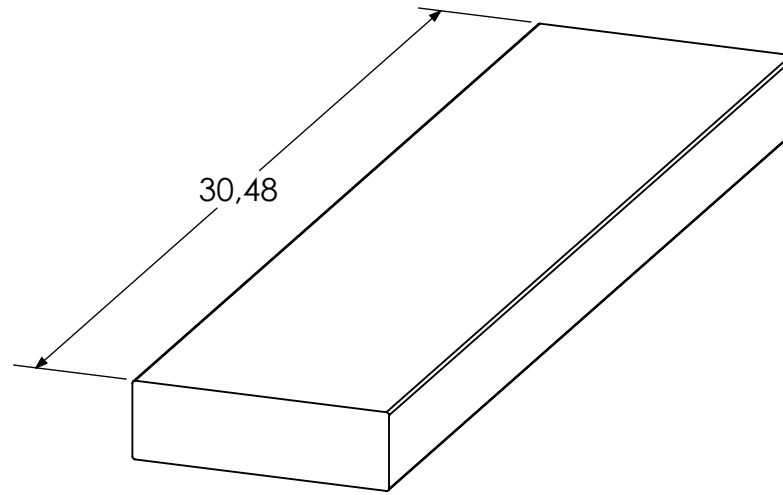

Polyex

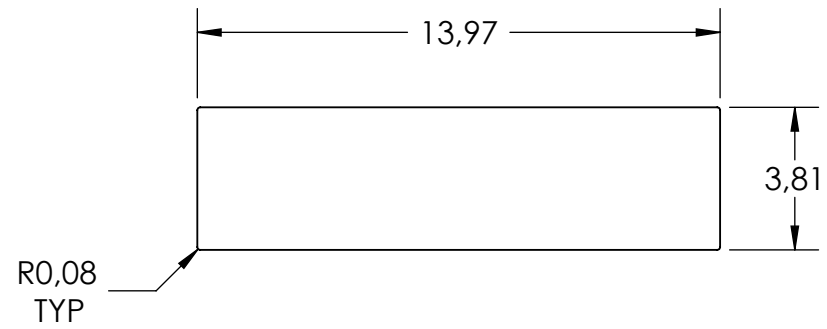
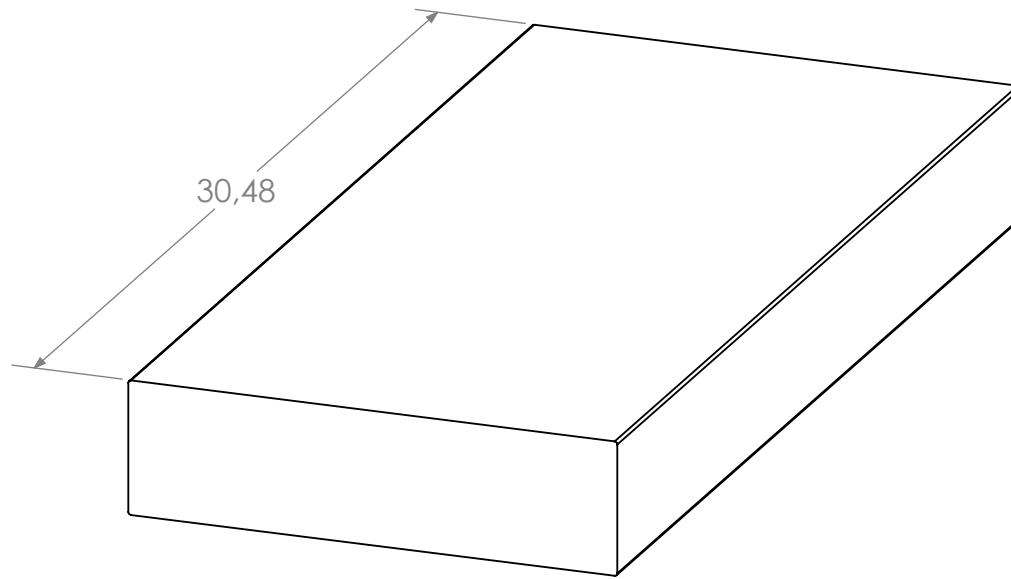

Polyex

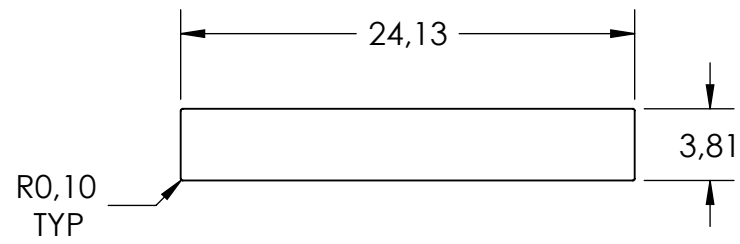
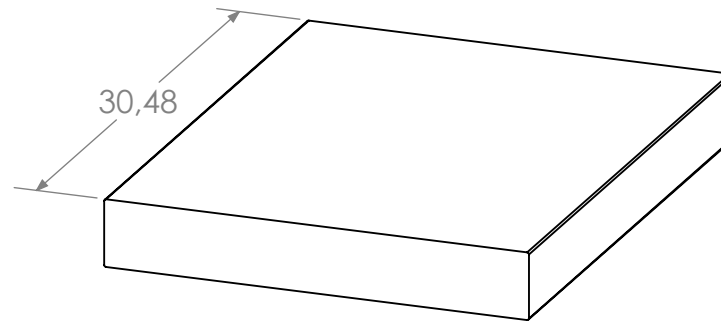

Polyex

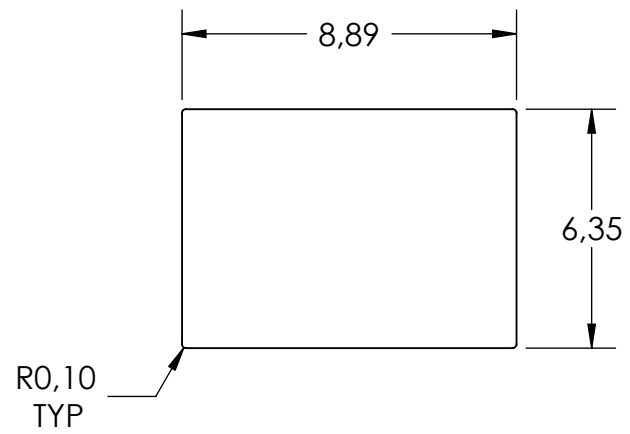
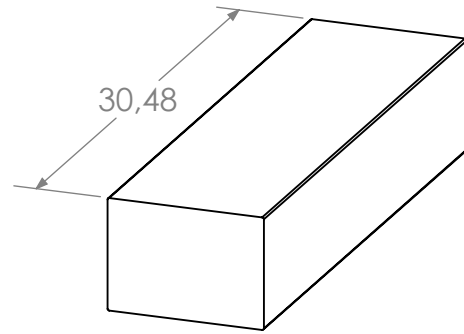

Polyex

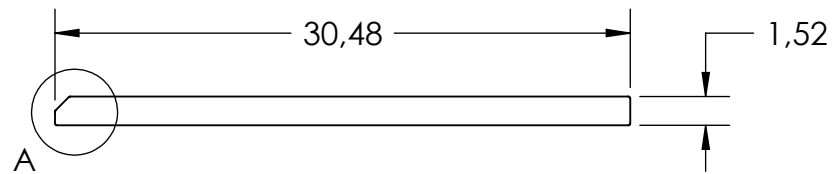
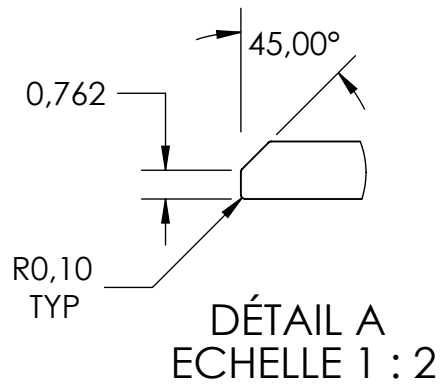
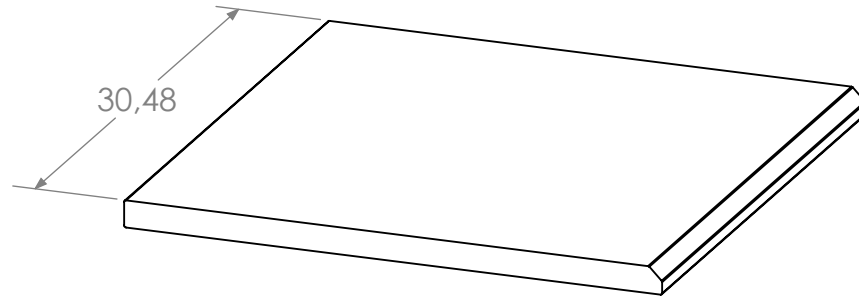

Polyex

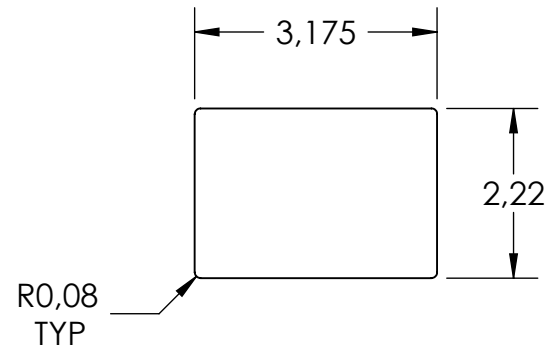
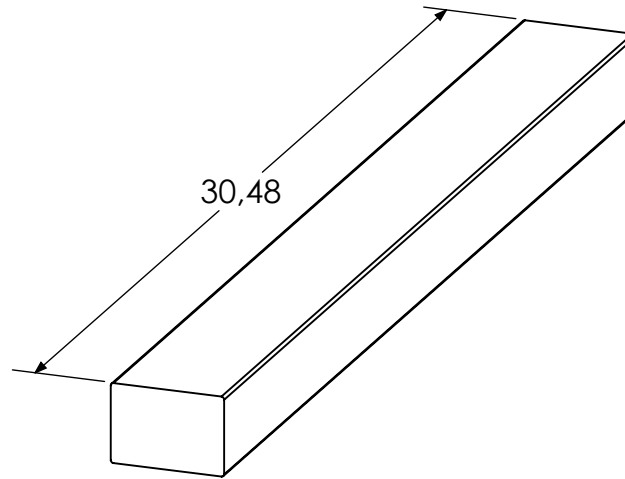

Polyex

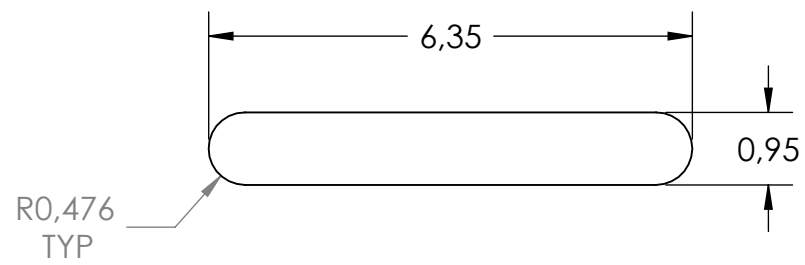
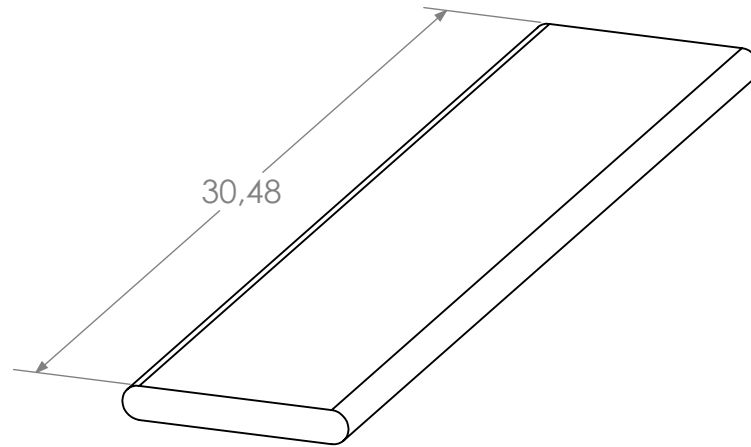

Polyex

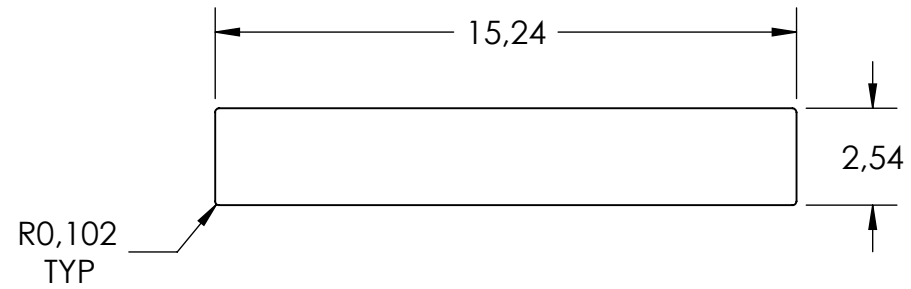
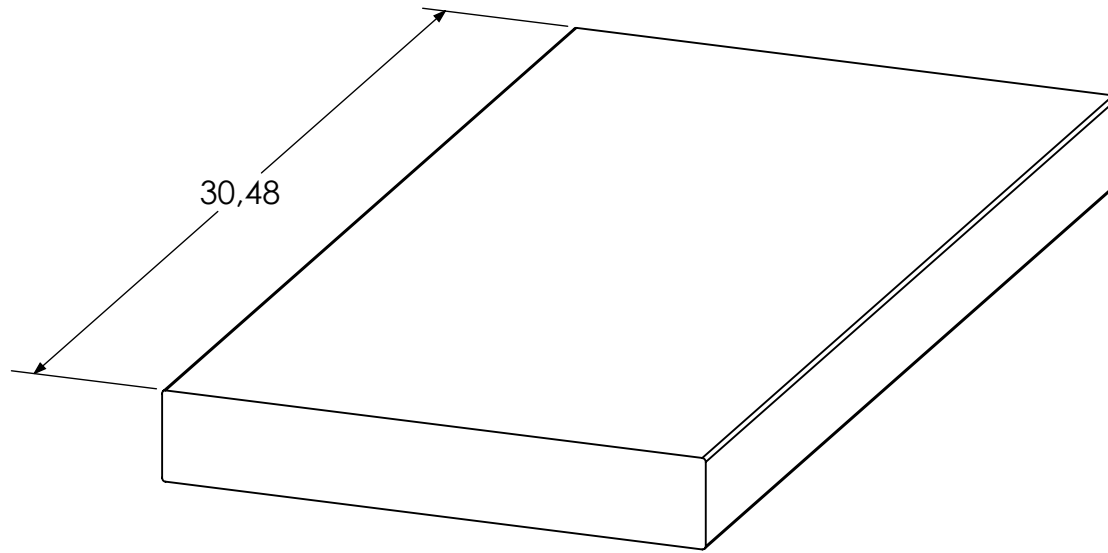

Polyex

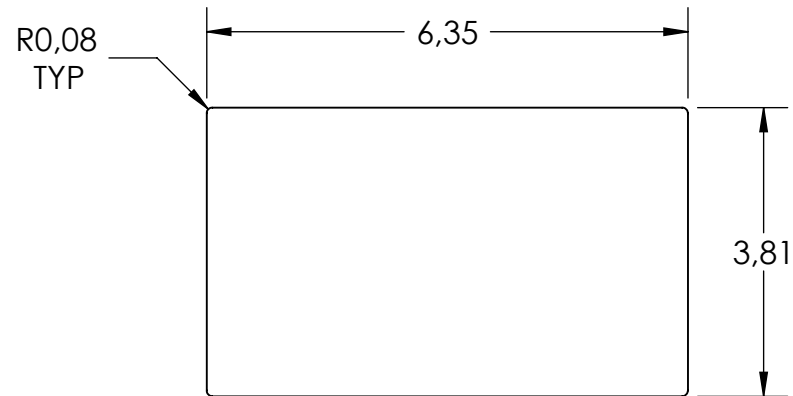
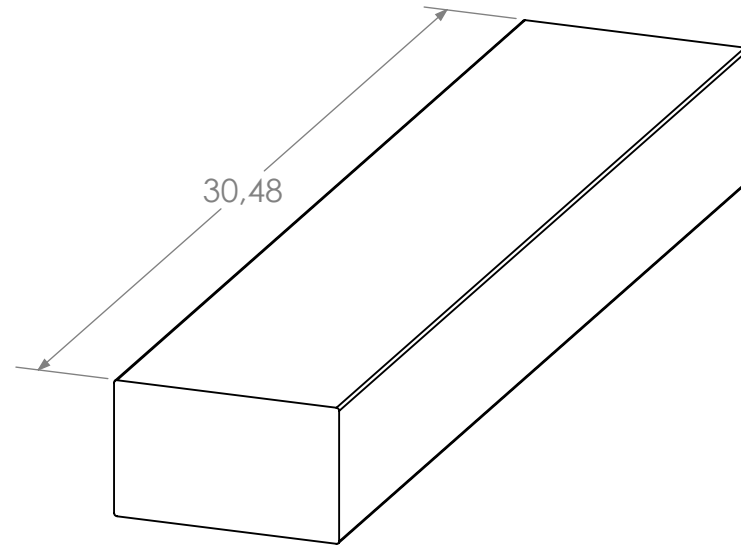

Polyex

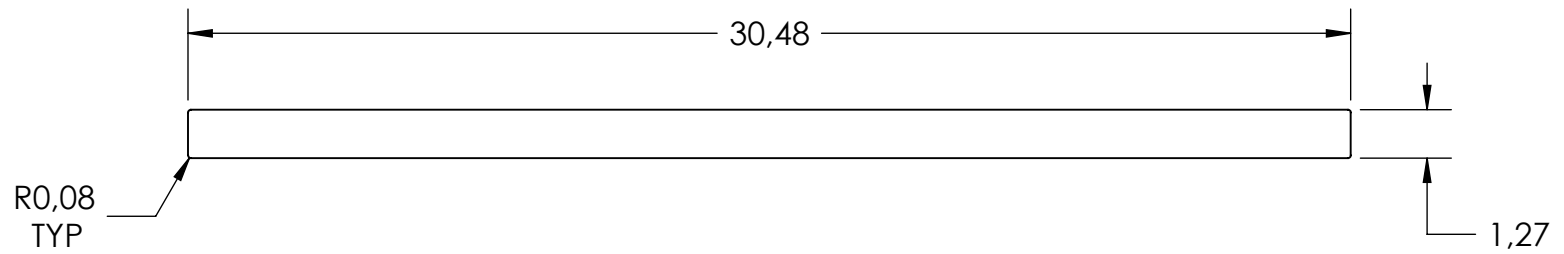
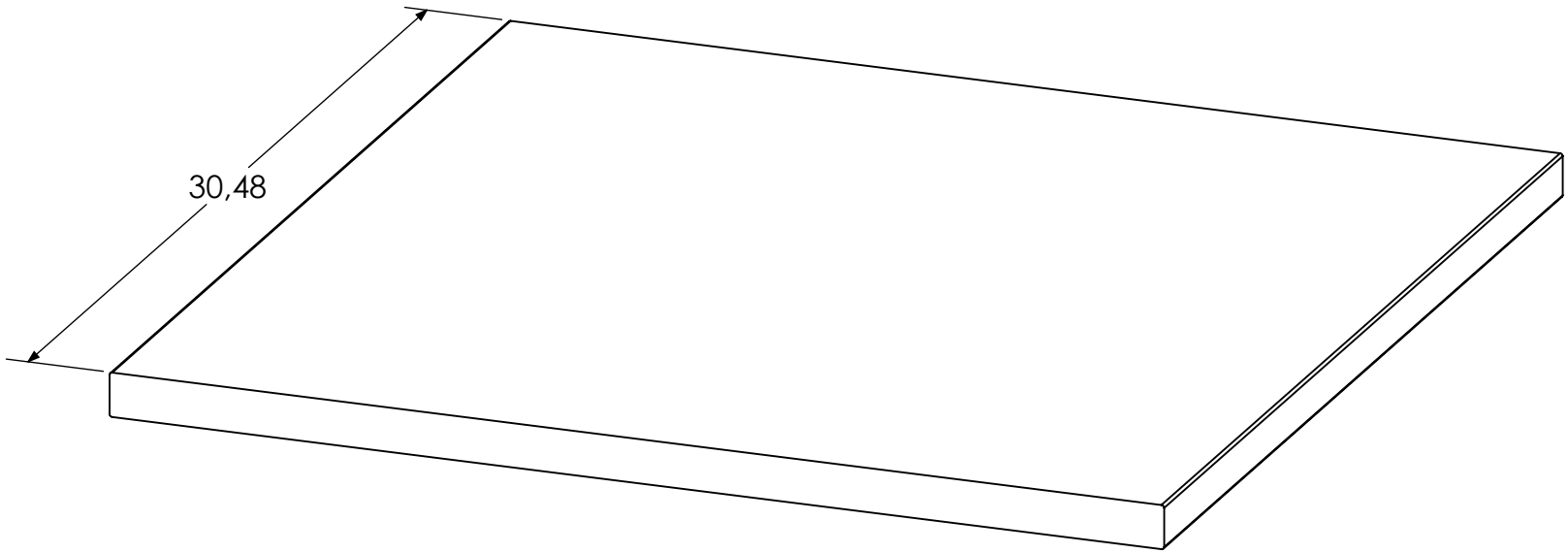

Polyex

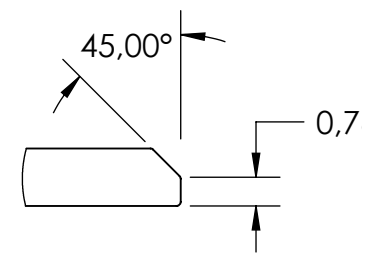
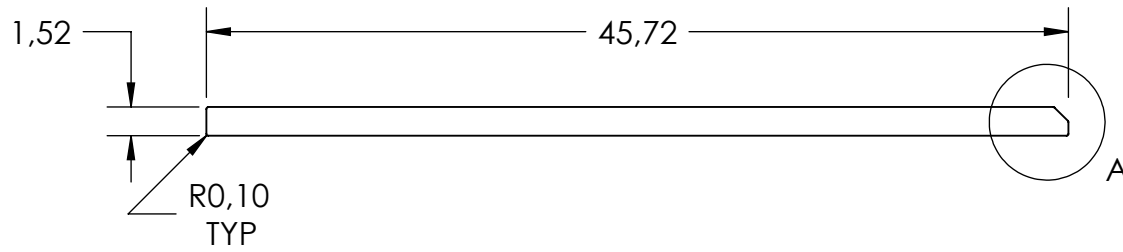
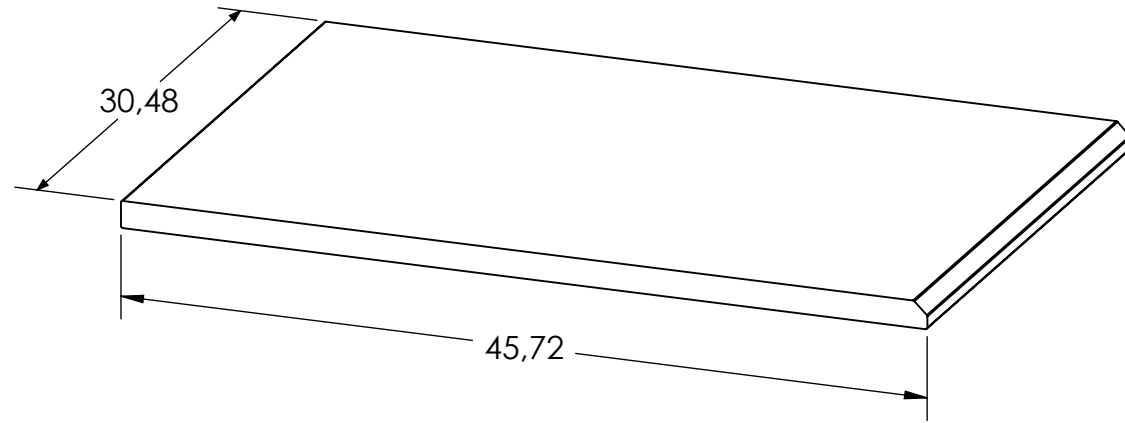

DÉTAIL A
ECHELLE 1 : 2

Polyex

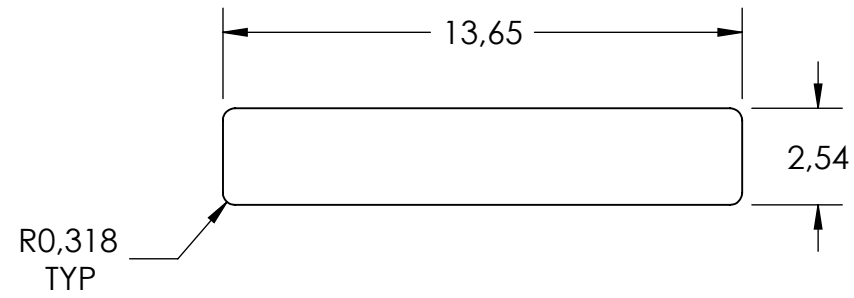
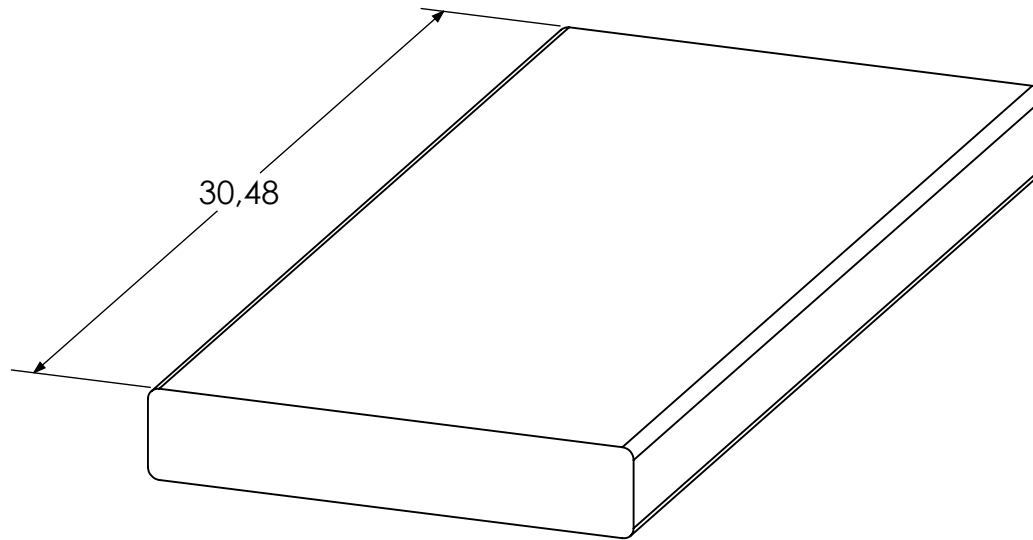

Polyex

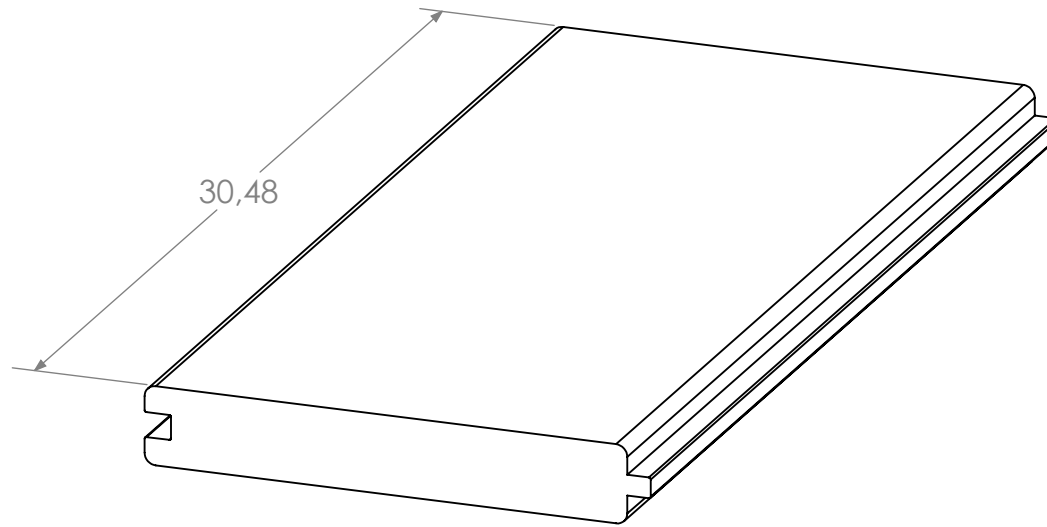

Polyex

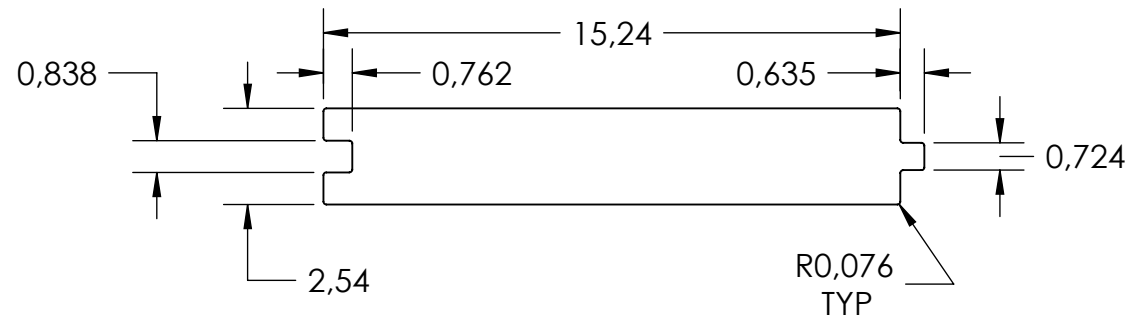
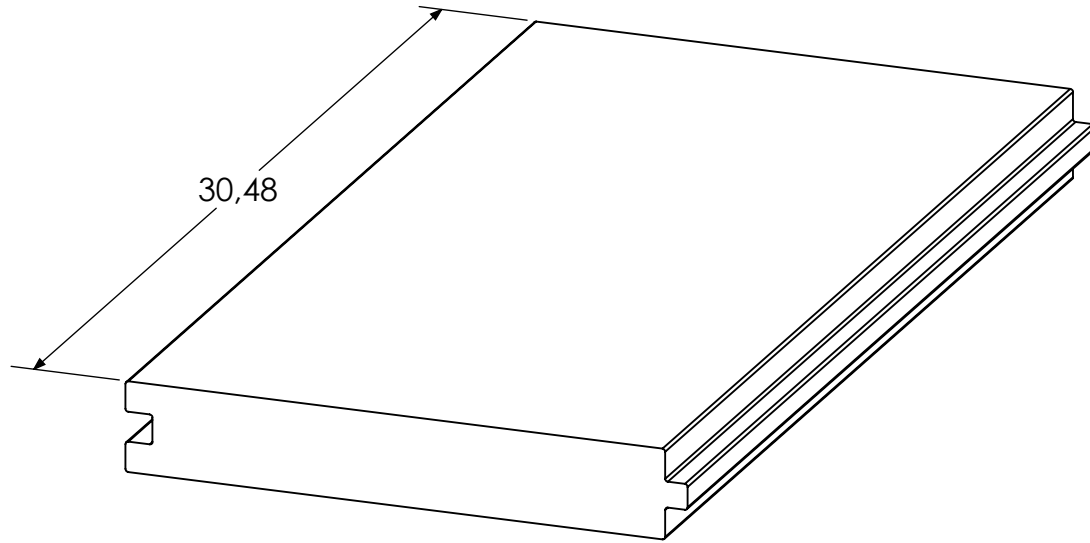

Polyex

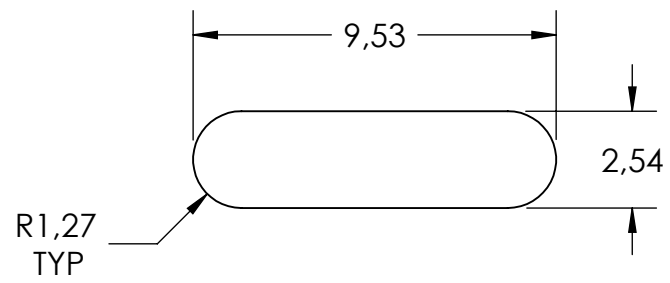
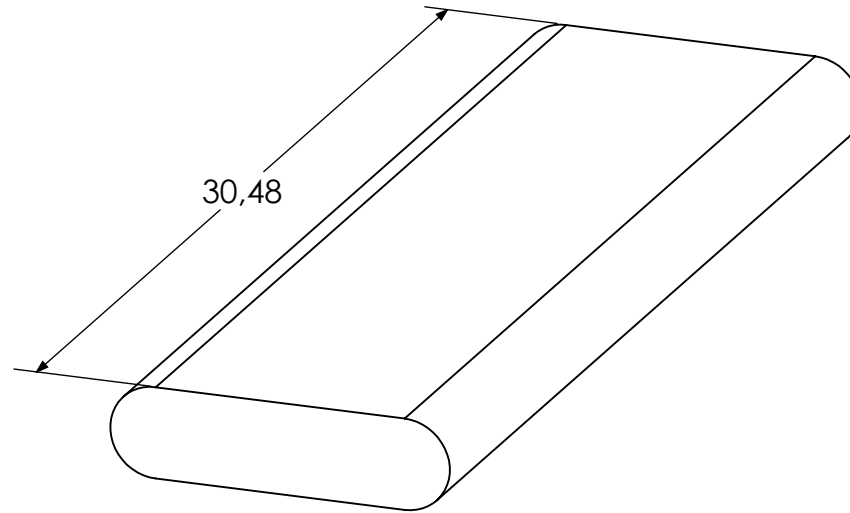

Polyex

